

# JACO<sup>2</sup>

## 4 DOF

*Technical specifications*



# JACO<sup>2</sup> 4 DOF

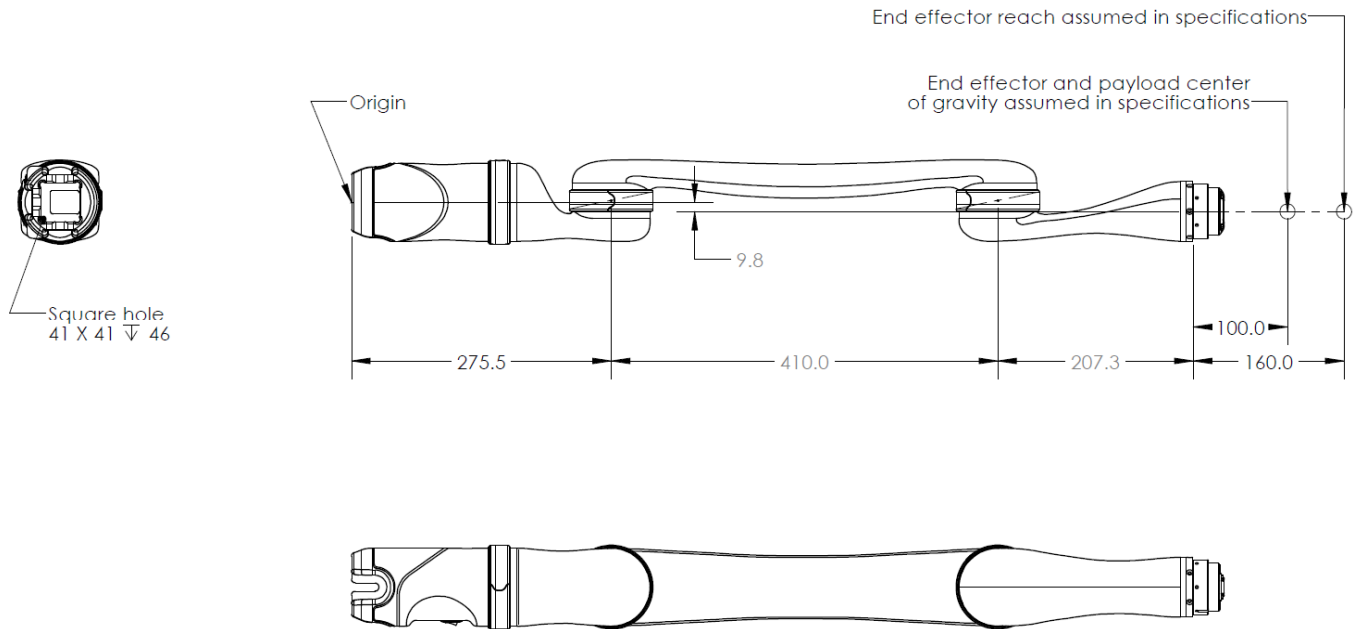

## GENERAL

TOTAL WEIGHT	3.6 Kg
MATERIALS	Carbon fiber (links), Aluminum (actuators)
PAYLOAD	4.4 Kg (mid-range continuous payload capabilities) 3.5 Kg (full-reach peak/temporary payload capabilities)
MAXIMUM REACH	75 cm
JOINT RANGE AFTER START-UP (SOFTWARE LIMITATION)	$\pm 27.7$ turns
MAXIMUM LINEAR ARM SPEED	20 cm/s
POWER SUPPLY VOLTAGE	18 to 29 VDC
AVERAGE POWER	25 W (5W in STANDBY)
PEAK POWER	100 W
COMMUNICATION PROTOCOL	RS485
COMMUNICATION CABLES	20 pins flat flex cable
2 EXPANSION PINS ON COMMUNICATION BUS	
WATER RESISTANCE	IPX2
OPERATING TEMPERATURE	-10 °C to 40 °C expected

## CONTROLLER

### PORTS

*Joystick*

*Power supply*

*USB 2.0 (API)*

*Ethernet*

1 Mbps CANBUS

18 to 29 VDC

12 Mbps

Not Available

### CONTROL SYSTEM FREQUENCY

100 Hz (High Level API)

500 Hz (Low Level API)

### CPU

360 MHz

### SDK

APIs

High and low level

Compatibility

Windows, Linux Ubuntu & ROS

Port

USB 2.0

Programming languages

C++

FORCE, CARTESIAN & ANGULAR CONTROL

---

## DETAILED SPECIFICATIONS

ACTUATORS #1 & #3

K-75

ACTUATOR #2

K-75+

ACTUATOR #4

K-58

---



6110 Doris-Lussier  
Boisbriand, QC, Canada  
J7H 0E8

[Kinovarobotics.com](http://Kinovarobotics.com)